



# MANUAL DE INSTALACION

## Sistema de Enganche Reforzado ST5 SE008

Ford F-100 Mod. 1998 +

### 1 CONTENIDO

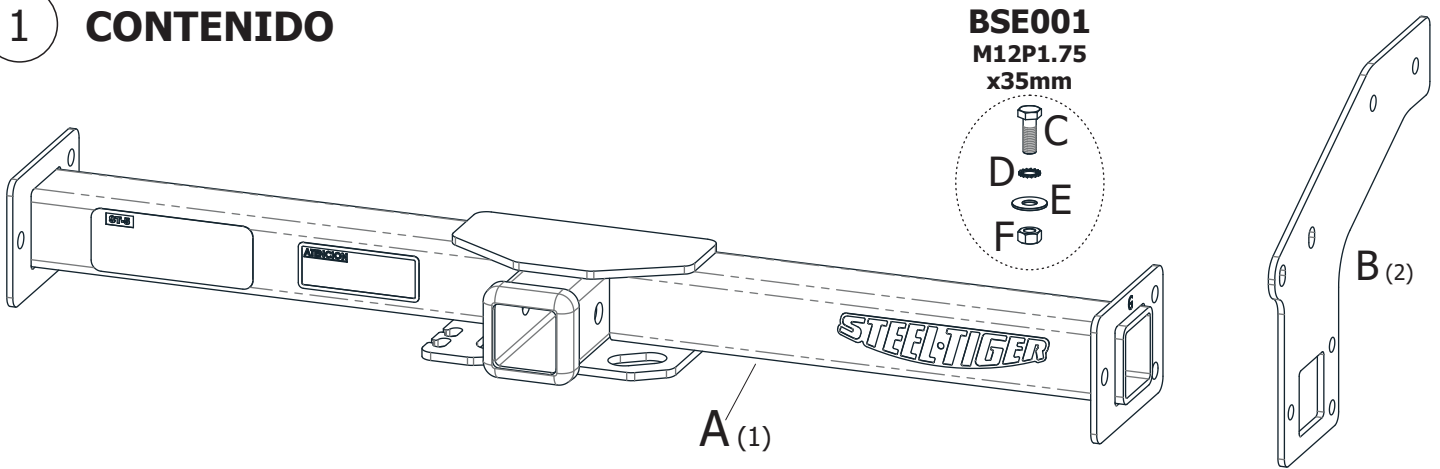

### 2 HERRAMIENTAS NECESARIAS

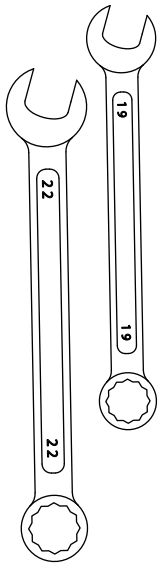

### 3 COLOCACIÓN DE PIEZAS "B"

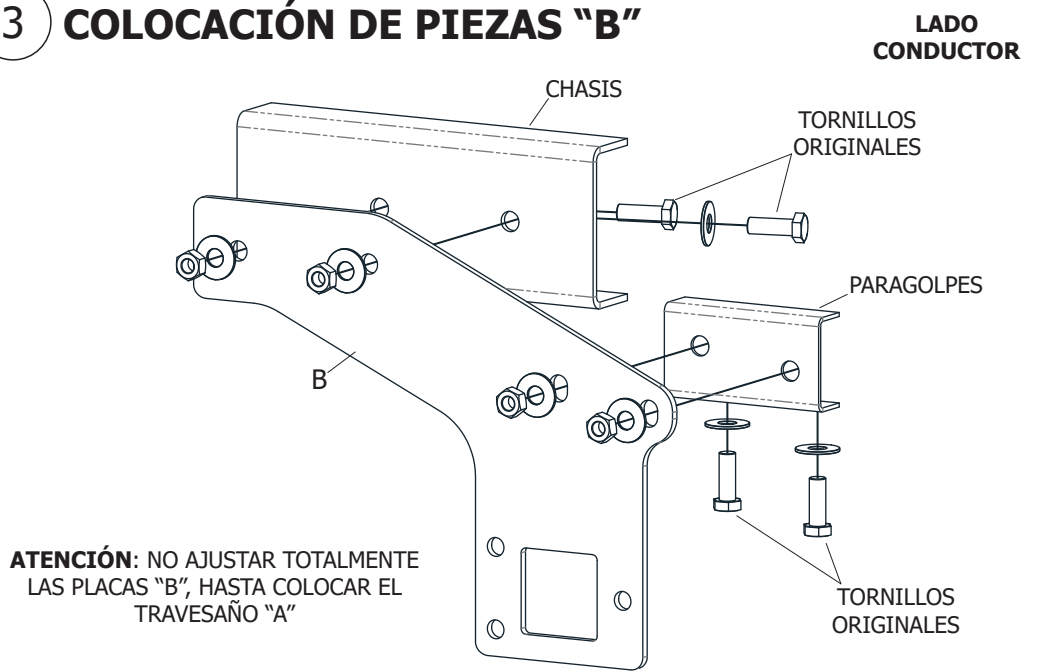

### 4 COLOCACIÓN DE PIEZA "A"

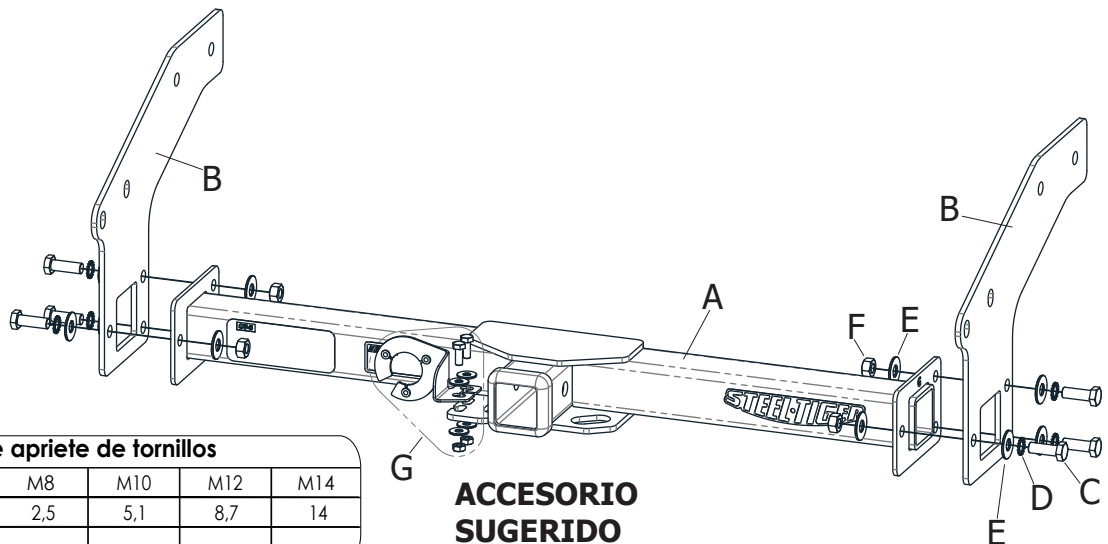

#### Valores de apriete de tornillos

Unidades	M4	M6	M8	M10	M12	M14
Kg.m	0,3	1	2,5	5,1	8,7	14

Coefficiente de fricción:  $\mu=0,14$